

**Standard-Werkzeuge
Standard-Tools
Outils standard
Utensili standard**

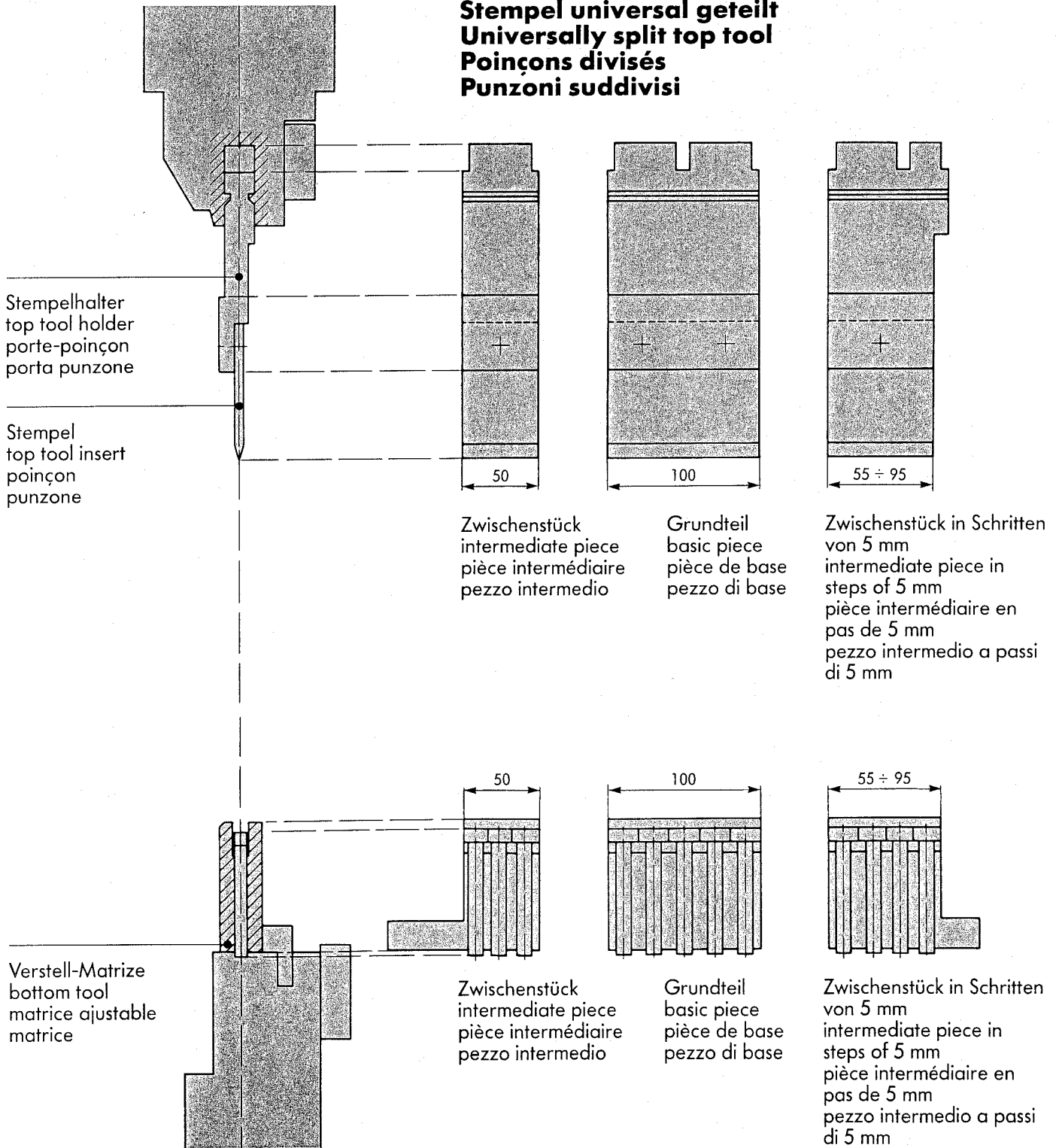

Stempel universal geteilt
Universally split top tool
Poinçons divisés
Punzoni suddivisi



**Flachdrücken
Hemming
Aplanir
Appiattare**

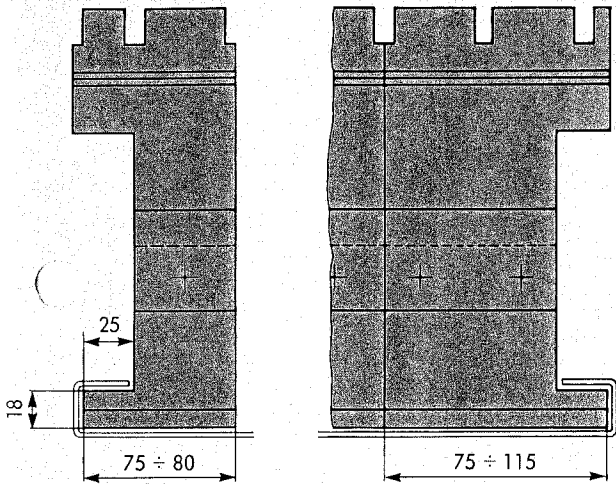

Hornstück
intermediate piece with
side horn
pièce intermédiaire
avec bigorne
pezzo intermedio con
corno laterale

Hornstück in Schritten
von 10 mm
intermediate piece with
side horn in steps of
10 mm
pièce intermédiaire
avec bigorne en pas
de 10 mm
pezzo intermedio con
corno laterale a passi
di 10 mm

Flachdrückkante
gehärtet
hemming edge
hardened
face trempée pour
aplanissement
spigolo di lavoro
temperato

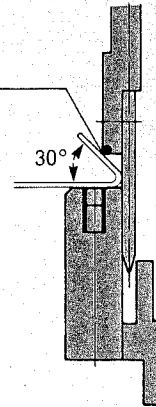

Stahlblech
bis 3mm

Matrize universal geteilt inkl. Bolzen
Universally split bottom tool incl. bolts
Matrice divisée incl. chandelles
Matrice suddivisa con perni

31.005.00

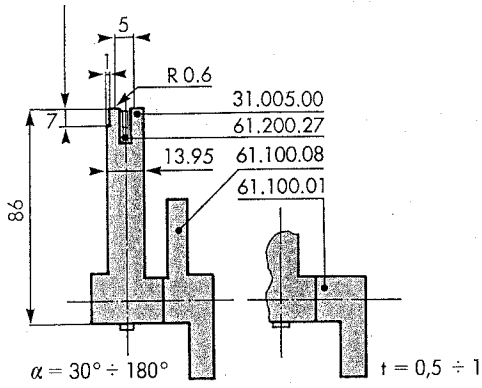

31.007.00

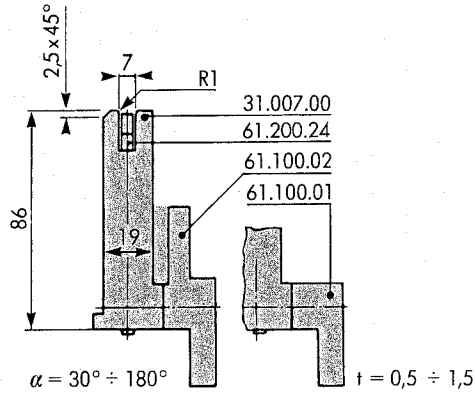

31.007.20

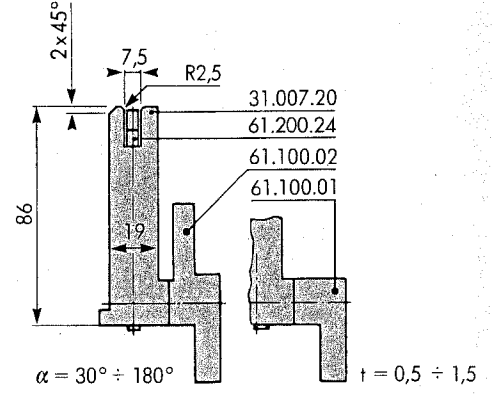

31.016.00

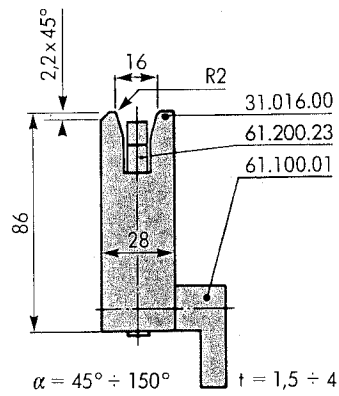

31.016.10

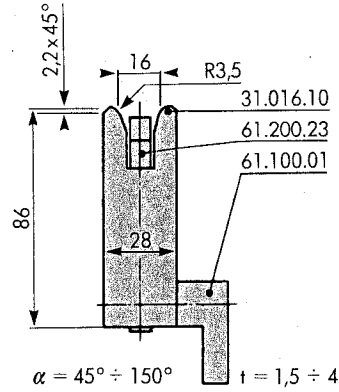

31.021.00

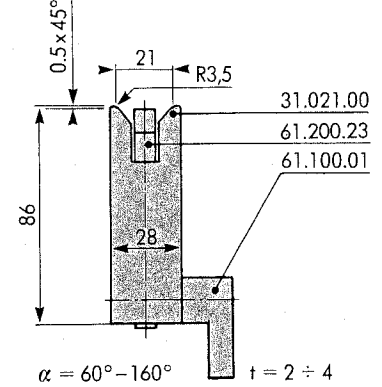

31.032.00

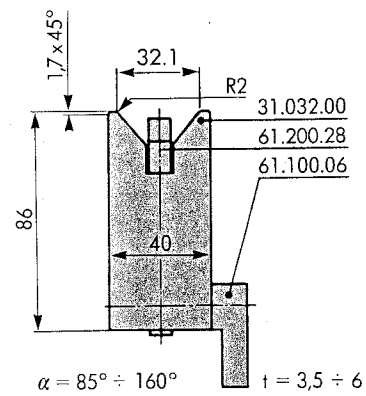

31.040.10

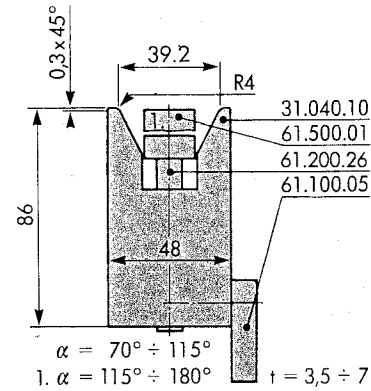

31.060.00

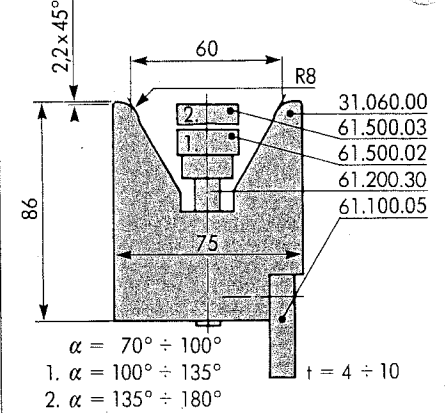

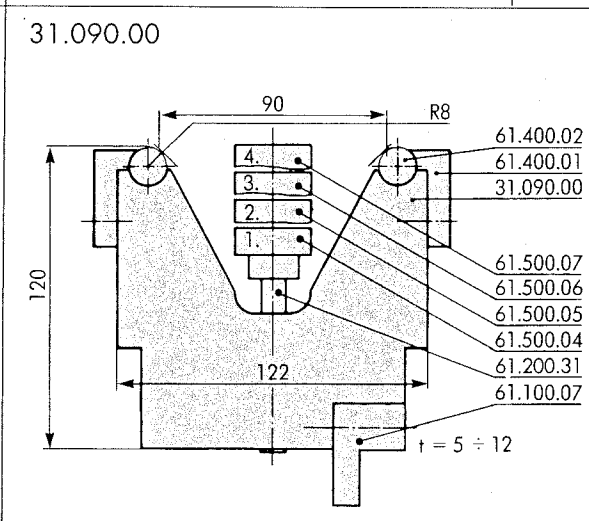
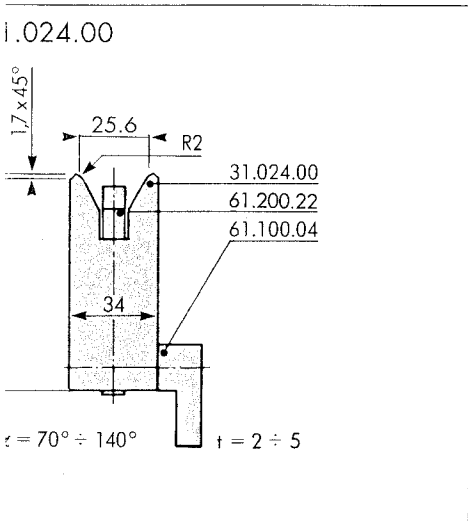
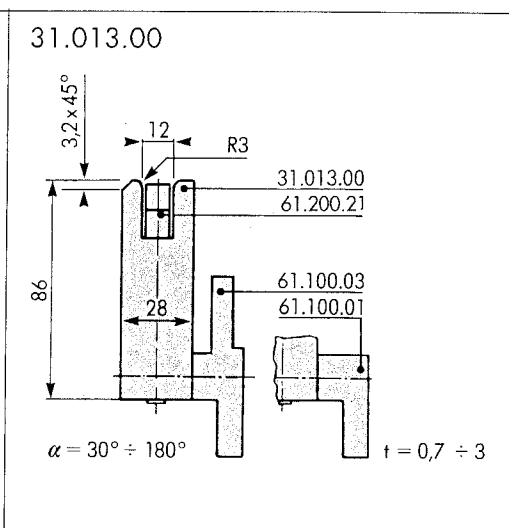
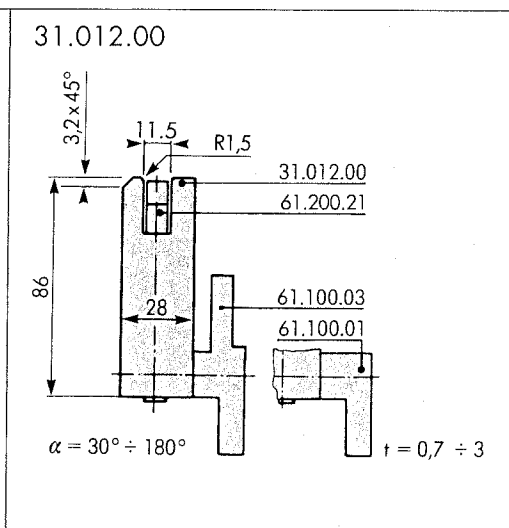
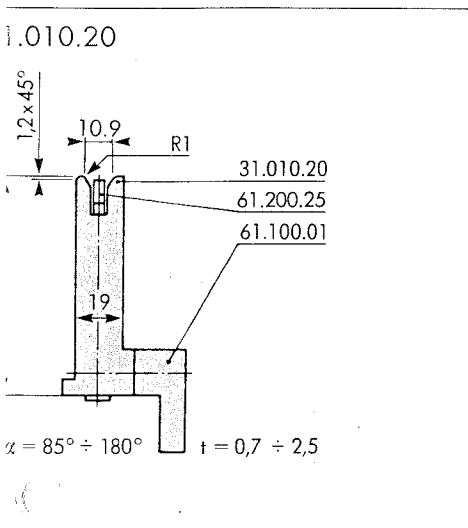

Verbreiterte Frontplatte erforderlich.
 Enlarged frontplate necessary.
 Plaque frontal pour élargissement nécessaire.
 Piastra frontale ampliata necessaria.

$\alpha = 70^\circ \div 75^\circ$
 1. $\alpha = 75^\circ \div 95^\circ$
 2. $\alpha = 95^\circ \div 120^\circ$
 3. $\alpha = 120^\circ \div 150^\circ$
 4. $\alpha = 150^\circ \div 180^\circ$

Verbreiterte Frontplatte erforderlich.
 Enlarged frontplate necessary.
 Plaque frontal pour élargissement nécessaire.
 Piastra frontale ampliata necessaria.

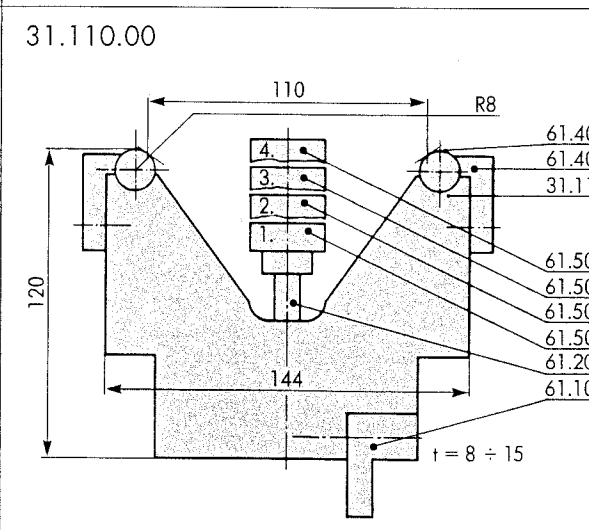

Verbreiterte Frontplatte erforderlich.
 Enlarged frontplate necessary.
 Plaque frontal pour élargissement nécessaire.
 Piastra frontale ampliata necessaria.

$\alpha = 75^\circ \div 90^\circ$
 1. $\alpha = 90^\circ \div 108^\circ$
 2. $\alpha = 108^\circ \div 130^\circ$
 3. $\alpha = 130^\circ \div 155^\circ$
 4. $\alpha = 155^\circ \div 180^\circ$

für Stahlblech

Stempel Poinçons
 Top tools Punzoni

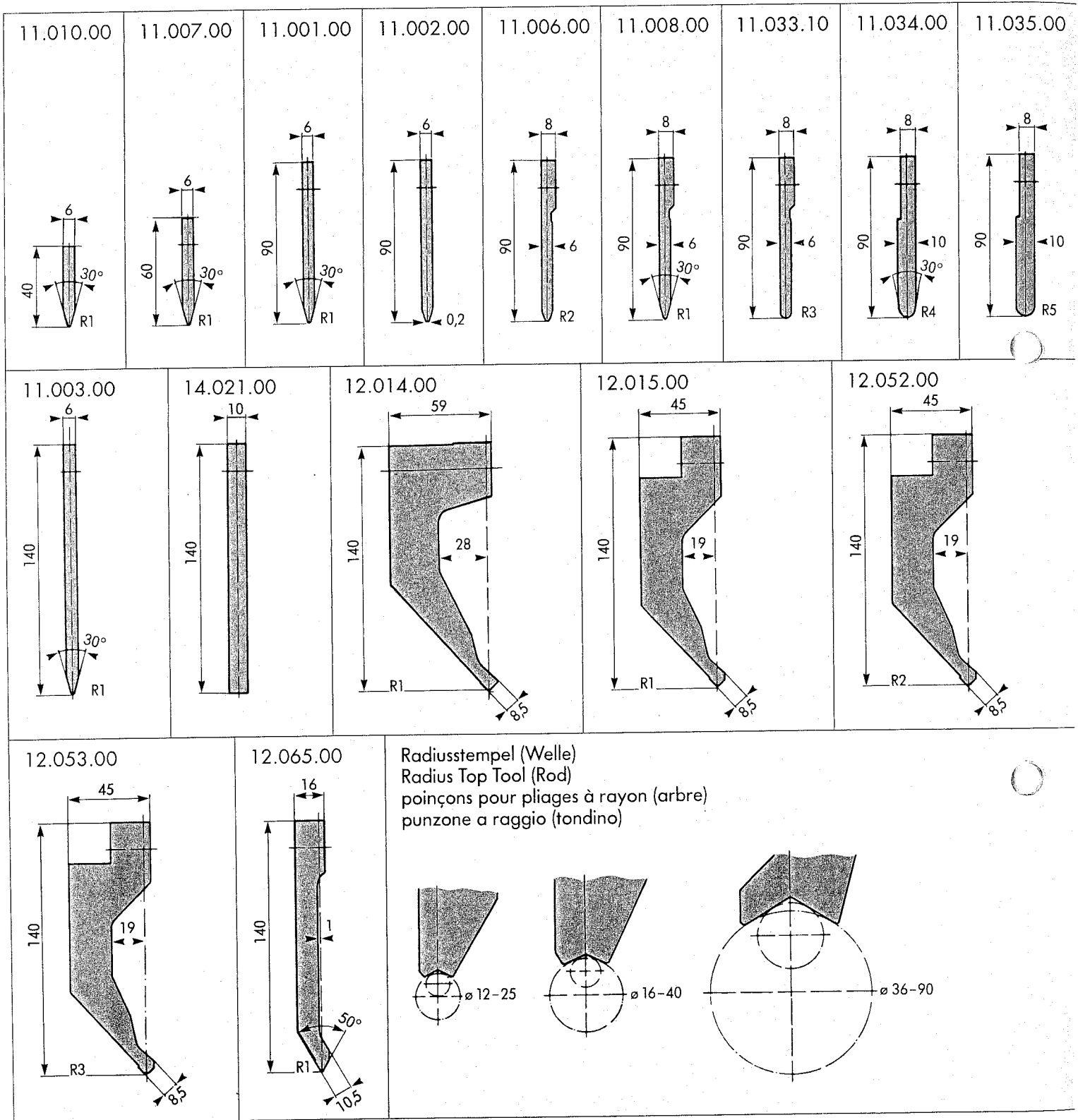

Stempelhalter
Top tool holders

Porte poinçons
Porta punzoni

HAMMERLE

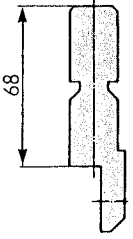
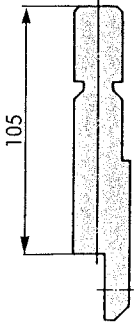
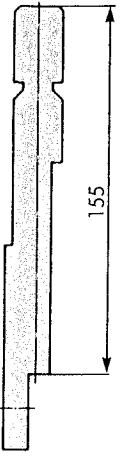
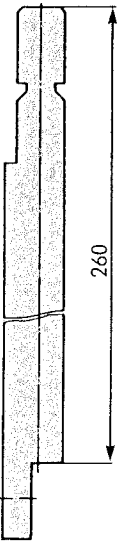
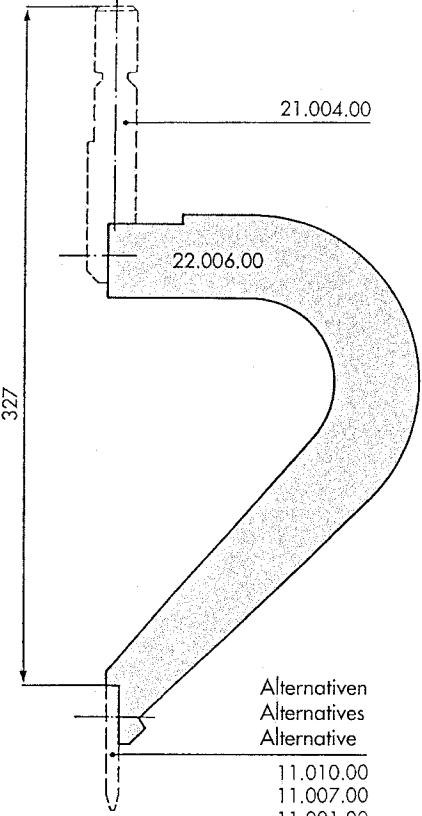
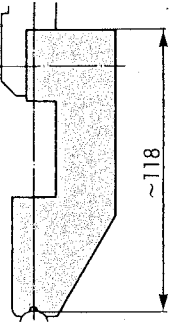
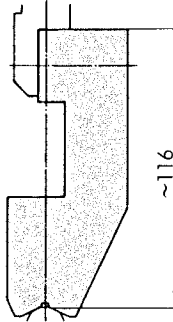
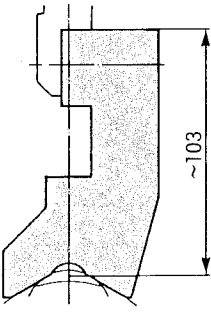
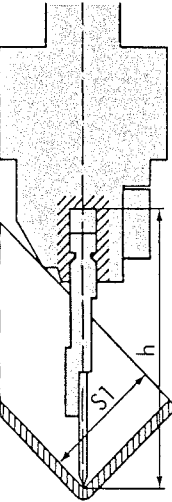
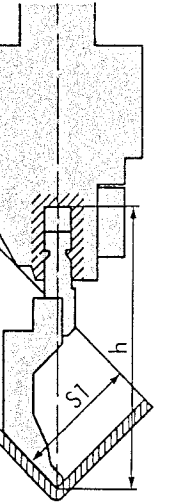
<p>21.003.00</p>  <p>68</p>	<p>21.004.00</p>  <p>105</p>	<p>21.002.00</p>  <p>155</p>	<p>21.005.00</p>  <p>260</p>	<p>22.006.00</p>  <p>21.004.00</p> <p>22.006.00</p> <p>327</p> <p>Alternativen Alternatives Alternative</p> <p>11.010.00 11.007.00 11.001.00 11.003.00</p> <p>(Einbauhöhe beachten) (Notice daylight of M/C) (Respecter hauteur pour montage outils) (Rispettare altezza di montaggio per utensili)</p>														
<p>22.013.00</p>  <p>~118</p>	<p>22.014.00</p>  <p>~116</p>	<p>22.015.00</p>  <p>~103</p>																
		<p>Kombinationen: Combinations: Combinaisons: Combinazioni:</p> <p>Beispiele examples exemples esempi</p> <table border="1"> <thead> <tr> <th>h (mm)</th> <th>S1¹⁾ (mm)</th> <th>Stempel/Stempelhalter Top tool holder Poinçon/porte poinçons Punzoni/porta punzoni</th> </tr> </thead> <tbody> <tr> <td>245</td> <td>110</td> <td>11.001.00 / 21.002.00 11.006.00 / 21.002.00 12.015.00 / 21.004.00</td> </tr> <tr> <td>295</td> <td>145</td> <td>11.003.00 / 21.002.00²⁾ 12.065.00 / 21.002.00</td> </tr> <tr> <td>350</td> <td>184</td> <td>11.001.00 / 21.005.00</td> </tr> <tr> <td>400</td> <td>219</td> <td>12.015.00 / 21.005.00</td> </tr> </tbody> </table>	h (mm)	S1 ¹⁾ (mm)	Stempel/Stempelhalter Top tool holder Poinçon/porte poinçons Punzoni/porta punzoni	245	110	11.001.00 / 21.002.00 11.006.00 / 21.002.00 12.015.00 / 21.004.00	295	145	11.003.00 / 21.002.00 ²⁾ 12.065.00 / 21.002.00	350	184	11.001.00 / 21.005.00	400	219	12.015.00 / 21.005.00	<p>1) S1 = maximale Bordhöhe max. height of side flange hauteur de la côté laterale max.</p> <p>2) Flachdrücken nicht möglich hemming not possible aplanissement pas possible appiattimento non possibile</p>
h (mm)	S1 ¹⁾ (mm)	Stempel/Stempelhalter Top tool holder Poinçon/porte poinçons Punzoni/porta punzoni																
245	110	11.001.00 / 21.002.00 11.006.00 / 21.002.00 12.015.00 / 21.004.00																
295	145	11.003.00 / 21.002.00 ²⁾ 12.065.00 / 21.002.00																
350	184	11.001.00 / 21.005.00																
400	219	12.015.00 / 21.005.00																

Ein Unternehmen
der Gruppe

M+S

Prägematrizen und Prägestempel
Planishing bottom and top tools
Matrices et poinçons à la frappe
Matrici e punzoni per coniare

Wir behalten uns Änderungen bezüglich der Angaben und Daten dieses Prospektes ausdrücklich vor.

We reserve the right to make any alteration to the specifications of technical data without notice.

Nous nous reservons le droit de modifier les données de ce catalogue.

Ci riserviamo il diritto di apportare delle modifiche.

41.005.00

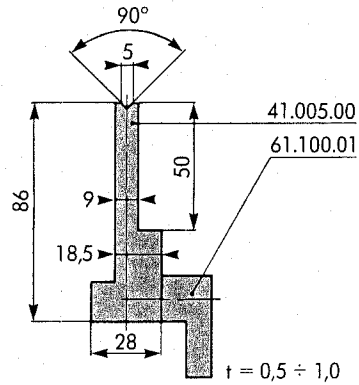

41.007.00

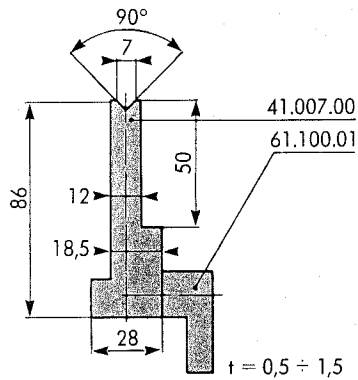

41.010.00

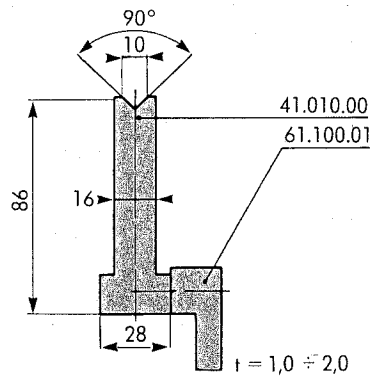

41.012.00

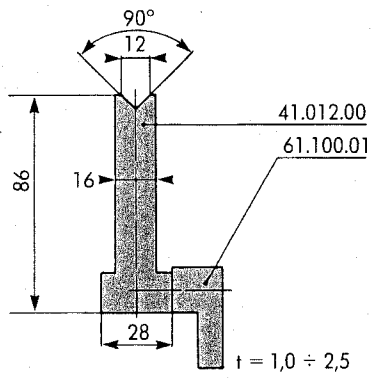

11.005.00

Nur für 41.005.00
 For 41.005.00 only
 Seulement pour
 41.005.00
 Solo per 41.005.00

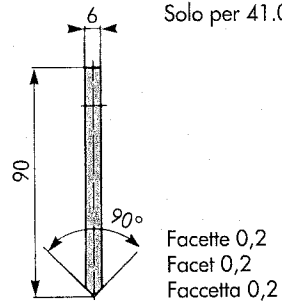

11.009.10

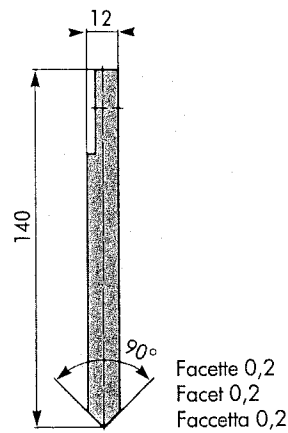

12.019.00

