

Numerical Control

DNC 15

The DNC 15 is the natural evolution of the world known DNC 880S. With a large 15-inch touch screen this DNC 15 gives the operator more power and easiness to control his machine.

Depending on the choice of software, DNC 15 can control synchronized press brakes or mechanical / hydraulic stops, as well as up-stroking or down-stroking press brakes (see the list of available versions next page).

This compact numerical control unit is available in 2 versions: 4 or 7 axes either in panel or box design.

Its Touch Screen 2D graphic software, its simple keyboard with large keys makes the use of this control very efficient and comfortable.

The basic functions are accessible by 6 subject-oriented keys giving access to clearly and logically designed menu pages. The bending solutions are displayed graphically in 2D and indicate possible collisions with the tools or the machine frame. The system also shows the position of the sheet within the tools.

The software enables the machine manufacturers to configure the axes, inputs/outputs and auxiliary functions according to their needs.

The DNC 15 is also fully compatible with our DNC 880S and 880 or DNC 80, making it an ideal control for retrofitting old machines.



Versions

The NC always comes with a PS version, PC, P, PL mode are created by the OEM in the machine parameters.

DNC 15 PS	For synchronized press brakes. 4 or 7 axes, 2 of them synchronized axes for the beam.
DNC 15 PC	Like DNC 15 PS, but for press brakes with mechanical (or hydraulic) stops and beam control by means of a linear encoder.
DNC 15 P	Same as DNC 15 PC, but without beam control by a linear encoder.)
DNC 15 PL	The PL version has been specifically developed for non-synchronized press brakes with hydraulic/electrical stops, but whose beam cycle is entirely controlled by the DNC by means of a linear encoder.

Standard software (axes and auxiliary functions)

The elements listed hereafter are available and can be configured in all numerical controls supplied with standard software (**within the number of axes and inputs/outputs available**).

Y1 - Y2	Synchronized axes for the beam (servo-valves, proportional valves). Should a current output be wanted, the MSV 402 accessory would be necessary.
X, X1, X2, X5, X6	Main rear backgauge axes.
X1 ABS, X2 REL	Secondary backgauge axes in absolute or relative mode.
R, R2, R5, R6	Backgauge height-adjustment axes.
Z, Z2, Z5, Z6	Axes for left/right movement of the backgauge.
Conical folds	Comfortable programming for conical folds (requires X, X2 and adapted stop fingers).
Free 1, 2, 3, 4	Independent axes without any particular control.
Pressure	Voltage output 0-10 VDC for pressure valve control. If current control is wanted, the MVP 100 voltage->current is the solution.
Crowning	Voltage output 0-10 VDC for adjusting the hydraulic crowning. If current control is wanted, the MVP 100 voltage->current is the solution.
F1 to F10	Configurable auxiliary functions (possibly, the number of AFs may be limited according to the type of function and management). 24 VDC voltage or logical order outputs, with or without position control by means of a potentiometer transducer. Special controls for gauge fingers, bending aids, die movements.
Languages	French, German, English, Italian, Spanish, Portuguese, Swedish, Danish, Finnish, Dutch, Hungarian, Polish, Czech, Slovene, Russian, Turkish, Chinese, Taiwanese. Other languages on request.
Particularities	Conversion Inch/mm, TON/ TONS etc. Measurement of speed, stopping time and leakage of the beam. Management of CE safety cycles. Interactive display of safety utilities and customized messages.

Software options (special axes, auxiliary functions, at extra cost)

M1, M2	Axes for the adjustment / movement of the die.
X3,X4,X7,X8,Z3,Z4	Front gauge axes.
H, H2	Rear sheet support axes (not calculated).
H3, H4	Calculated front sheet support axes.

Accessories

CybVA_6	Interface card for Hörbiger proportional valves.
MVP 100	Voltage / current conversion module (0-10V → 0-0.5 / 0-2 A) for pressure and crowning valves, to be fitted in the electric cabinet.
MSV 402	Voltage / current conversion module (±10V → ±50 mA, ±300 mA) for servo-valves.

Technical characteristics

Multiprocessor design using ASIC and SMD components. This allows high integration and ensures great reliability.

Keyboard	Large keys easy to use with working gloves.
Screen	15 inch colour Touch Screen .
System	Windows XP Embedded
CPU	LX 800
RAM	256 MB (standard version).
Mass memory	Compact Flash (1 GB).
Port	4 USB 1.1 (2x external, 2x internal). 1 parallel (printer). 1 RS232. 1 RJ45 Ethernet 1 VGA
Axes	High counting speed axes (250 KHz), with PID regulator and programmable resolution.
Power supplies NC	+ 24 VDC $\pm 10\%$, 2A (~ 50W).
Power supplies for digital inputs/outputs	+ 24 VDC $\pm 10\%$
Incremental encoder inputs	5 VDC line drivers.
Digital inputs	16 optocoupled inputs. 24 VDC stabilized $\pm 10\%$.
Analogic inputs	8 inputs 0-10 VDC.
Digital outputs	16 optocoupled outputs. 24 VDC, max. 0.3 A / output.
Voltage outputs (axes)	4 or 7 outputs ± 10 VDC, output impedance $Z_{out} = 100 \Omega$, load $Z_I \geq 10 \text{ k}\Omega$.
Analog voltage outputs (functions pressure, crowning or auxiliary functions)	2 outputs 0-10 VDC, output impedance $Z_{out} = 100 \Omega$, load $Z_I \geq 10 \text{ k}\Omega$.
Temperature, pollution level, relative humidity and height during work	Min. 5° Celsius, max. 40° Celsius. * Pollution level 2. Relative humidity (10 to 85% non condensing). Max. height 2000 m. * if the temperature exceeds 40° C, forced cooling (ventilation, air-conditioning) must be provided.
Weight	Approx. 5 kg (panel version), approx 15 kg (box version)
EC Directives	IEC61131-2

Box version

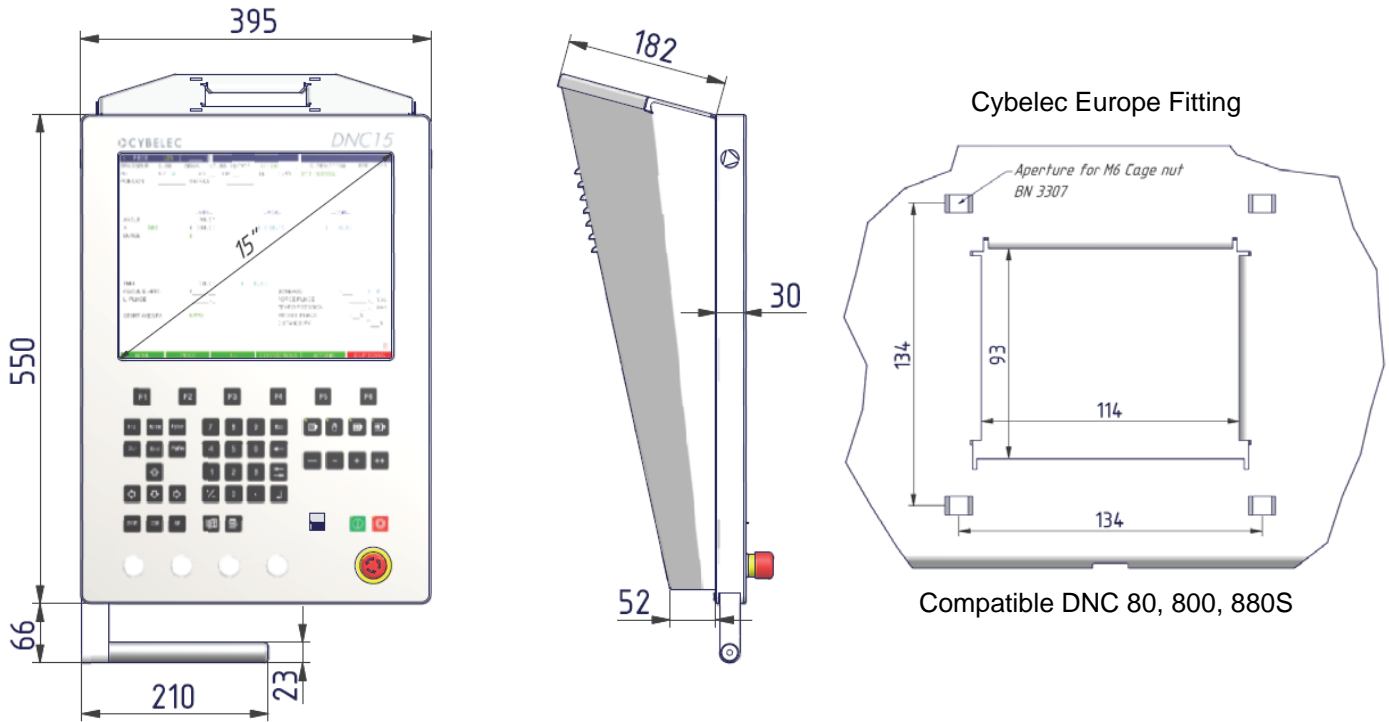

Panel version

